

Hydraulic Spike Puller 910199 Operating Manual



Hydraulic Spike Puller

910199

Record of Changes

Rev No.	Date	Description of Changes
Rev 1	2.2024	Initial release.

Table of Contents

Section 1: Overview and Safety	5
Hydraulic Spike Puller	5
Environmental Protection	5
Safety Information	5
Safety Terms	6
Machine Use and Safety Precautions	6
Section 2: Specifications and Installation.....	7
Components	8
Installation	9
Hose Requirements	10
Hose Types	10
Hydraulic Hose Recommendation	11
Hydraulic Fluid Recommendation	11
Tool Connecting Procedures	12
Disconnecting Hoses	13
Section 3: Tool Operation	13
Personal Protective Equipment	13
Operation.....	13
Section 4: Maintenance.....	14
Jaw Removal	15
Jaw Replacement	15
Troubleshooting	16
Section 5: Parts and Service Support	17
Spike Puller / RRP# 465393 [Rev 13 (5.2019)]	18
Spike Puller / RRP# 465393 Parts List.....	19
Section 6: Warranty Terms and Conditions	20

This page was intentionally left blank.

Section 1: Overview and Safety

Hydraulic Spike Puller

Racine Railroad Products designs and manufactures equipment primarily for the repair and new construction of rail and railroad tie track maintenance.

The Spike Puller is the fastest puller in the marketplace offering 13,000 lbs of pull force. Jaws are in a ready to pull position when approaching the spike and the jaws automatically release the spike as the trigger is disengaged.

Patented Lower Chute Design

The unique lower chute design minimizes the kick during pulling. The lower leg incorporates reinforced bottom and enclosed chute to eliminate spike jams. The jaws are easily repaired/replaced or converted to hairpin jaws via the side panel.

Do not use this machine for other than its intended purpose.

Please read these instructions when using this tool, which can only be used for the specified purpose. Failure to do so could result in personal injury or equipment damage. This instruction manual should be kept throughout the life of the tool.

Note: Information in this document is subject to change without notice.

The operator of this tool should:

- Have access to this operation instruction.
- Read and understand this operation instruction.

Environmental Protection



Comply with relevant national waste disposal laws and regulations. Waste electronic devices cannot be treated as household waste.

Equipment, accessories, and packaging shall be recyclable.



Do not throw the discarded equipment in trash cans.

Safety Information

For safe installation and operation of this equipment, carefully read and understand the contents of this manual. Improper operation, handling, or maintenance can result in equipment damage and personal injury.

Only trained and authorized personnel should be allowed to operate this machine. In addition, all personnel at the worksite (gang) should be aware of the safety concerns and their individual responsibilities prior to working with this machine.

Please read and comply with all the safety precautions in this manual **before** operating this machine. Your safety is at risk.

Safety Terms



DANGER indicates a hazardous operating procedure, practice, or condition. If the hazardous situation is not avoided death or serious injury will occur.



WARNING indicates a hazardous operating procedure, practice, or condition. If the hazardous situation is not avoided death or serious injury could occur.



CAUTION indicates a potentially hazardous operating procedure, practice, or condition. If the hazardous situation is not avoided moderate or minor injury could occur.

Machine Use and Safety Precautions



Failure to follow safety precautions when operating this equipment can result in serious injury or death to the operator or other persons in the area.

Observe the following precautions whenever you are operating, working on or near this equipment.

Do not make any modifications without authorization or written approval from Racine Railroad Products. Replace all Racine Railroad Products and OEM parts with genuine Racine Railroad Products and OEM parts. Using non-OEM parts may compromise the safety of the machine.

Do not wear loose clothing, jewelry, radio belts, etc., when operating, working on or near this equipment. They can be caught in moving parts and may result in severe injury.

Always wear appropriate personal protective clothing when operating this equipment: e.g., orange safety vest, hard hat, safety glasses with side shields, hearing protection, steel-toed safety boots, leather gloves, dust respirator, etc.

Always lift heavy objects with the knees and legs, not the arms and back.

Always keep hands, arms, feet, head, clothing, etc., out of the operating area and away from all rotating or moving components when operating, working on or near this machine.

Always make sure that all guards, covers, belts, hoses, and operating components are in good working order and that all controls are in the appropriate position before starting the engine.

Always make sure that all safety equipment installed properly and are in good working order. Do not operate the machine until unsafe conditions have been corrected.

Always operate in a well-ventilated area and make sure that the air filters, air filter covers, and muffler are in good condition.

Always keep the machine clean and free of debris. Operate the machine in a safe and responsible manner. Exercise caution when fueling, working on or near rotating or moving components, hot components, and fuel systems. Be aware of potential fire hazards and prevent sparks, exhaust, etc., from starting fires on the machine and/or work area.

Always comply with all instructions provided on any decals or placards installed on the machine and with any relevant amplifying information provided in this manual or other general operating procedures.

Always disconnect the power source and make sure that all controls are in a safe position and install all appropriate locking and safety devices before doing any of the following:

- Lubricating
- Adjusting
- Installing Tooling
- Making Repairs
- Performing Service

Section 2: Specifications and Installation

Hydraulic System..... Open Center

Length..... 35.00 in. (~88.9 cm)

Width..... 16.00 in. (~40.6 cm)

Height, Work Mode..... 4.00 in. (~10.2 cm)

Weight: (with hoses) 49 lbs (~22.2 kg)

Hydraulic Motor

Flow Range..... 5-10 gpm (~19-38 lpm)

Pressure Range..... 1500-2000 psi (~103-138 bar)

Maximum Extraction Time 5-second average

Pulling Force..... 12,500 lbs @ 2000 psi (~5,670 kg @ 138 bar)

Production Rate..... Extracts 6 to 10 spikes per minute.

Hydraulic Systems

Use a calibrated flow meter and pressure gauge to check the hydraulic power source for 5 -10 gpm /19-30 lpm at 1500-2000 psi /103-138 bar.

A relief valve setting between 2100-2250 psi / 145-155 bar is required for the operation.

The hydraulic system's back pressure should be less than 250 psi / 17 bar, measured at the tool end of the operating hoses.

All system's checks should be made at minimum operating temperatures (maximum fluid viscosity of 400 ssu / 82 centistokes).

The hydraulic fluid cooling system should limit maximum fluid temperature to 140° F/ 60° C at the maximum expected ambient temperature.

Components

The Hydraulic Spike Puller is comprised of the upper control body, flow control valve with lever and whip

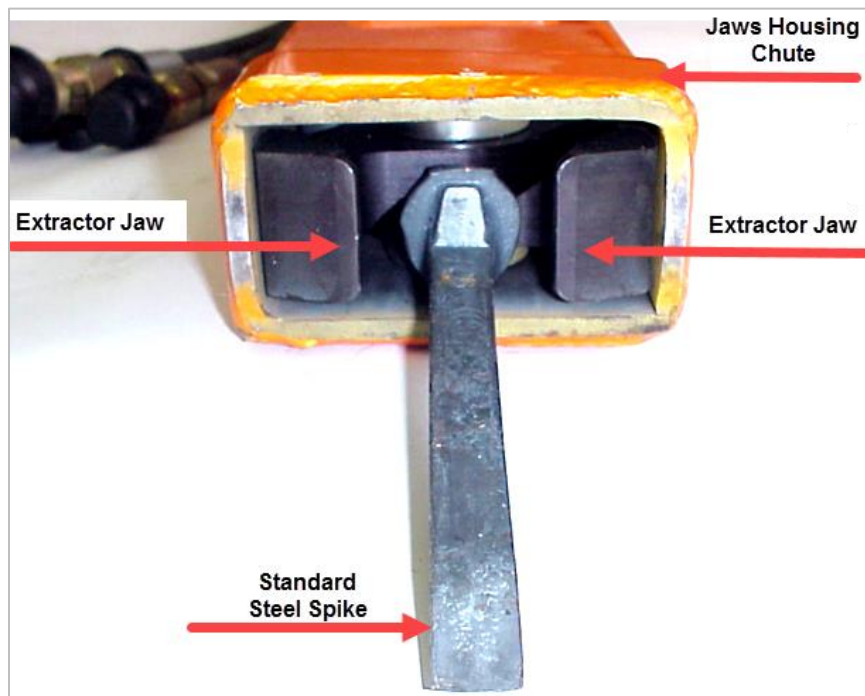
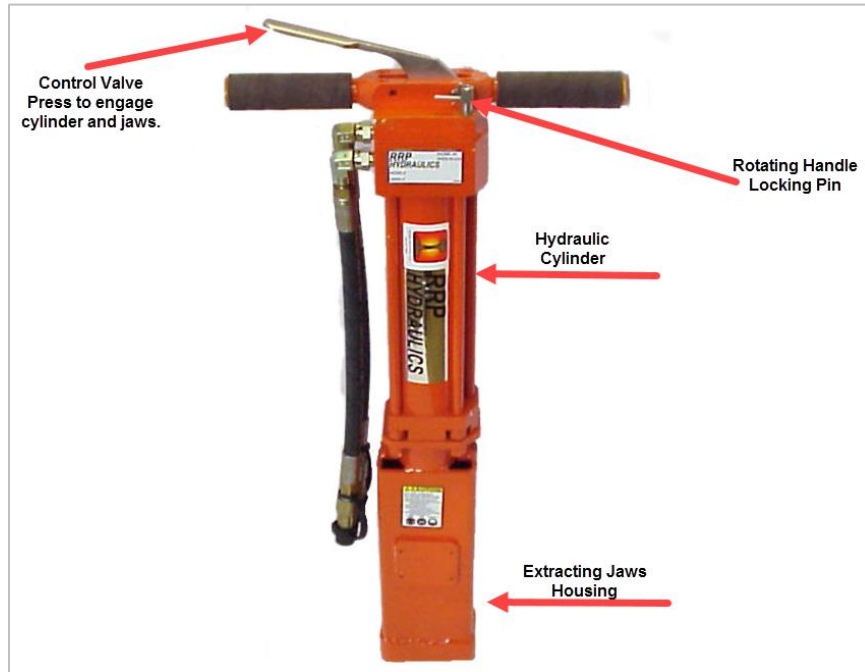

Installation

**WARNING**

Never stick foreign objects, fingers, or other extremities into the moving mechanism. Failure to follow these instructions may lead to severe personal injury or tool damage.

Unpacking Instructions

Upon receiving your Hydraulic Spike Puller promptly remove it from the shipping container. Always keep the top side of container up. Inspect unit for damage which may have incurred during shipping and report it to carrier for claim.

Tool Preparations

If the tool is used in cold weather, preheat the hydraulic fluid by running the power source at low engine speed.

Fluid temperature should be at or above 50° F/10° C (400-ssu / 82 centistoke) before use, when using recommended fluids. Using too thick of fluid may result in tool damage.

The Racine Hydraulic 910098 power unit is recommended for hydraulic supply.

- This unit is equipped with two 5 gpm / 20 lpm circuits that can be combined for one 10 gpm / 38 lpm circuit.

Check that the power is open-center system. Do not use the Hydraulic Spike Puller with closed center system or tool damage may occur.

Tool Actuating Valve Lever Check

Check that handle valve lever is easily pressed toward for ON and returns to OFF position when released.

Pressing the valve lever on the handle will retract the cylinder, closing the jaws onto the spike head and pulls the mechanism further upward inside the chute.

The valve lever will return to the OFF position when released.

Release the valve lever to return the cylinder rod to full extension and free the extracted spike.

- If hydraulic control valve lever sticks or does not operate easily check for obstructions.
- If valve lever does not return to the OFF position when released, check the return springs.

**WARNING**

Do not operate the tool if the hydraulic control valve lever is not working.

Hose Requirements

Recommended hose size: .500 inch / 13mm I.D. up to 50 ft / 15 m long

Recommended hose size: .625 inch / 16 mm I.D. up to 100 ft / 30 m long

It is not often necessary or advisable to use long hoses. All hoses must have an oil resistant inner surface and an abrasion resistant outer surface. Each hose must have male pipe ends for most application.

Longer hoses can be used when necessary but can affect the operation of the tool due to resistance in the hose.

If small diameter or long hoses are used, or if restrictive fittings are connected to the supply and return ports, the pressure required to push the fluid through the system and back to the tank will be higher. This will reduce tool power.

Important: Oil should always flow from the male coupler through the female coupler.

Note: The pressure increases in uncoupled hoses left in the sun. This may make it difficult to connect. When possible after use, connect the free ends of the operating hoses together.

Hose Types

Hydraulic hose types authorized for use with the Hydraulic Spike Puller are:

1. **Labeled and certified non-conductive.**

- This is the only hose authorized for use near electrical conductors.
- Constructed of thermoplastic or synthetic rubber inner tube, synthetic fiber braid reinforcement, and weather resistant thermoplastic or synthetic rubber cover.

2. **Wire braided** (conductive)

- This hose is conductive and must **never** be used near electrical conductors.
- Constructed of synthetic rubber inner tube, single or double wire braid reinforcement, and weather resistant synthetic rubber cover

3. **Fiber braided** (not certified or labeled non-conductive)

- This hose is conductive and must **never** be used near electrical conductors.
- Constructed of thermoplastic or synthetic rubber inner tube, synthetic fiber braid reinforcement, and weather resistant thermoplastic or synthetic rubber cover.

The rated working pressure of the hydraulic hose must be at least 175 bar (2500 psi).

Hydraulic Hose Recommendation

Hydraulic Hose Recommendation								
Flow Per Circuit		Length Each Hose		Use	Inside Diameter		SAE Spec Hose (Wire Braid)	SAE Spec Hose (Fiber Braid)
GPM	LPM	Feet	Meter		Inch	MM		
5 to 8	19 to 30	To 50	To 15	Both	1/2	13	SAE 100R1-8	100R7-8
5 to 8	19 to 30	51 to 100	15 to 30	Both	5/8	16	SAE 100R2-10	SAE 100R8-10
5 to 8	19 to 30	100 to 300	30 to 90	Pressure Return	5/8 3/4	16 19	SAE 100R2-10 SAE 100R1-12	SAE 100R8-10 SAE 100R7-12
9 to 12	34 to 45	To 50	To 15	Both	5/8	16	SAE 100R2-10	SAE 100R8-10
9 v 12	34 to 45	51 to 100	15 to 30	Pressure Return	5/8 3/4	16 19	SAE 100R2-10 SAE 100R3-12	SAE 100R8-10 SAE 100R7-12
9 to 12	24 to 45	100 to 200	30 to 60	Pressure Return	3/4 1	19 25.4	SAE 100R2-12 SAE 100R1-16	SAE 100R8-12 SAE100R7-16

The rated working pressure of the hydraulic hose must be at least 2500 psi / 173 bar.

Hydraulic Fluid Recommendation

Inspect hoses for cuts, crushing, leaks, or abrasion, which may be a safety hazard or reduce fluid flows.

The following fluids work well over a wide temperature range at startup, allow moisture to settle out, and resist biological growth likely in cool operating hydraulic circuits.

Others that meet or exceeds the specifications of these fluids may also be used.

Type	Hydraulic fluid
Chevron	Clarity AW 15032
Exxon	Univis J 32
Mobil	D.T.E. 13M
Gulf	Harmony AW-HVI-150-32
Shell	Tellus T 32
Texaco	Rando HDZ 32
Union	Unax AW-WR-32
Amsoil	AWH 15032
Sunvis	Low Pour H/032-product code 19300

Tool Connecting Procedures

1. Stop the engine before connecting the tool and or hoses to the power unit, and when switching hoses or tools.
2. Turn the hydraulic on/off valve to the off position before starting the engine.

Make sure all hoses are connected for correct flow direction to and from the tool being used.

When routing hose in the work area, position them where personnel will not be at risk of tripping over them where vehicles can run over the hoses. Do not lay hose over sharp objects.



WARNING

Pressurized fluid escaping from a damaged hose can penetrate the skin and be injected in the body causing injury or death.

Do not pull on hoses to drag the power unit or tool.

Connecting Hoses

1. Wipe quick couplers with a clean lint free cloth before connecting them.
2. Depressurize the system.
3. Allow system and hydraulic fluid to cool if too hot to handle.
4. Securely connect the return (tank “R”) hose from the power source to the tool.
5. Securely connect the supply (pressure “P”) hose from the power source to the tool.

It is recommended that you connect the return hoses first and disconnect last to minimize or avoid trapping pressure within the tool.

When connecting the quick couplers, the flow should run from male coupler to the female coupler. The female coupler on the tool is the inlet. Quick couplers are marked with a flow direction arrow.



WARNING

Pressurized fluid escaping from a damaged hose can penetrate the skin and be injected in the body causing injury or death.

Do not pull on hoses to drag the power unit or tool.

Note: When possible, connect the free ends of uncoupled hoses to prevent build up in the hoses. The sun can also increase pressure in the hoses and make connecting them difficult.

1. Grip the handles firmly with both hands.
2. Pull down with thumb on the safety lock and pull the trigger to the handle to start the grinder.
3. When starting the tool, hold it off from all surfaces.
4. Start grinding with the tool running.
5. When finished, release trigger and allow stone to stop turning and make sure trigger is in the locked position before placing the tool on any surface.

Disconnecting Hoses

1. Stop the hydraulic power source.
2. Depressurize the system.
3. Allow system and hydraulic fluid to cool.
4. Disconnect the supply (pressure) hose from the power source (pressure port) from the tool (IN port).
5. Disconnect the return (tank) hose to the hydraulic power source (return port) from the tool (OUT port).
6. To prevent contamination, always install dust caps over the hydraulic ports of the tool when disconnected.

Section 3: Tool Operation

Personal Protective Equipment



Before operating this machine, make sure that all general safety precautions are observed, and that proper personal protective clothing is worn as described below.

At a minimum, operators should wear the following Personal Protective Equipment:

1. Safety Glasses
2. Hearing Protection
3. Hard Hat
4. High Visibility Safety Vest
5. Leather Work Gloves (outside the cab)
6. Steel Toed Safety Shoes

Operation

The Hydraulic Spike Puller is designed to efficiently extract railroad steel spikes imbedded in wooden cross-ties. The tool uses a hydraulic cylinder for power pulling spikes out and requires some degree of manual dexterity to control the tool.

The Hydraulic Spike Puller is equipped with an articulating jaws mechanism that grips the spike during the extraction phase.

1. Connect hydraulic power to the tool and it adjust for left or right hand operating preference.
2. Firmly grasp both handles and place the jaw chute end on the steel spike head.
3. Press the control valve spool lever toward the handle grip, activating the tool.

Always hold the tool with both hands to maintain control.

4. To stop the Spike Puller, release the control valve spool lever.

When the jaws encompass the spike head, the extraction interval should be a short span of time.

Excessive wear will occur to the extracting mechanism due to heat buildup.

Section 4: Maintenance

It is highly recommended to practice regular check-ups and maintenance in accordance with the usage frequency to keep your tool in better condition and reduces total running costs.



WARNING Do not perform maintenance on the Lad Driver while the hydraulic power source motor is running or when hoses are connected.

All maintenance must be done with the tool disconnected from the power source.

Cleaning and Maintenance Recommendations

- Wipe all external surfaces after each use with a clean, lint free cloth to remove surface contaminants from the tool.
- To extend the life of the handle padding, do not allow sharp edges or foreign objects to rub on the padding.
- Store all tools in an enclosed area to prevent the weather from contaminating their systems.

Safety Devices

When maintenance is complete, make sure the following:

- The hydraulic control valves are operable.
- The hydraulic quick couplers and hoses are safe to use.
- Weekly lubrication of the gripper cams and gripper arms.
- The gripper pads are in good condition.

Daily



WARNING Do not attempt to locate hydraulic leaks by feeling around hoses and fitting with hand. Pin-Hole leaks can penetrate the skin.

- Wipe all tool surfaces, fittings, and couplings free of grease, dirt, and foreign materials.
- Inspect the tool, hydraulic system, hoses, and fittings for signs of leaks, cracks, wear, and/or damage. Replace if necessary.
- To prevent contamination, always install dust caps over the hydraulic ports when disconnected.

Cold Weather Operation

Hydraulic fluids are thicker in cold weather; therefore, run the engine at low idle long enough to bring the fluid temperature up to minimum of 10°C/50°F or until the top of the hydraulic tank feels warm, before operating tool.

Storage Preparation

The tool should be stored in a cool, dry environment which is not subjected to rapid temperature changes.

- Cover male and female hose whips.
- Store in the upright position.
- Secure tool to prevent it from being knocked over.
- Store the Lag Driver on a smooth level surface.

Jaw Removal

1. Place the tool on a clean flat surface.
2. Remove the flat head screws from one cover plate.
3. Remove the friction cap.
4. Remove the clevis pin.
5. Slide the jaw assembly out of the lower chute.
6. Retrieve the second friction cap and two spacer guides, pivot pin and spring upon jaw removal.
7. Clean out debris from the chute and cover plates.

Jaw Replacement

1. Assemble the pivot pin, two spacer guides and lower friction cap into the jaw.
2. Slide the assembly into the chute.
3. Align the link holes to the clevis hole and install the clevis pin.
4. Install the spring into the pivot pin.
5. Install the second friction cap.
6. Install the window cover and securely fasten using the flat head screws.

Note: Complete disassembly of the tool is not recommended. If a complete disassembly is required, return the tool to Racine Railroad Products.

Troubleshooting

The following chart can be used as a guide to correct problems you may experience with the Hydraulic Spike Puller.

To determine the problem in operation of the Hydraulic Spike Puller, always check that the hydraulic power source is supplying the correct hydraulic flow and pressure to the tool as listed in the table. Be sure you are using an accurate flow-meter.

Check the flow with the hydraulic fluid temperature at least 80° F / 27° C. Always check the power source and hoses before disassembling the unit.

Problem	Possible Cause	Resolution
Performance sluggish, tool is too slow, or tool will not pull the spike.	Power source.	Check power source flows and pressure (10 gpm / 38 lpm @ 2000 psi / 103-138 bar).
	Hose or coupler blocked or improperly connected.	Remove restriction, ensure hoses and fittings are properly connected.
	Contaminated ball seat.	Change system fluid. Cycle tool several times at maximum flow. If not corrected, return for service.
	Fluid temperature.	Minimize fluid temperature 140°max.
	Excessive back pressure.	Minimize back pressure, 200 psi max.
	System pressure and flow inadequate.	
Jaws do not grab spike.	Broken jaws.	Replace or return for service.
	Jaws are not returning to HOME position when tool is in neutral.	Check hoses for proper connection. Hoses or connections may be reversed.
Fluid leak at handle.	Damaged spool seal.	Return for service.
Fluid leak at cylinder rod/jaws are wet.	Damaged cylinder rod or seal.	Return for service.

Section 5: Parts and Service Support

Telephone and web-based technical support is available for current production models through our Customer Service Department. Service Manuals and limited technical support may be available for models that are no longer in production.

Telephone and E-mail Technical Support

Telephone and e-mail technical support is available on normal U.S. business days from 8:00 AM to 5:00 PM U.S. Central Time Zone (GMT +6 (+5 Daylight Savings Time)).

Phone: (262) 637-9681

Email: custserv@racinerailroad.com

Racine Railroad Products
1955 Norwood Court
Mount Pleasant, WI 53403

Non-Warranty Technical Support

Depending upon the circumstances and availability of technical service personnel, we may provide technical assistance and/or field service support, *at the customer's expense*, to assist in the correction of non-warranty related problems. Contact our Customer Service Department to coordinate Non-Warranty Technical or Field Service Support.

Warranty Support Technical Support

Depending upon the circumstances and availability of technical service personnel, we may provide technical assistance and/or field service support, *at no charge to the customer*, to assist in the correction of warranty related problems. Contact our Customer Service Department to coordinate Warranty Technical or Field Service Support.

Warranty Parts Claims

Material claimed to be defective must be returned to our factory for evaluation. Defective materials will be replaced, or your account will be credited if replacement materials have already been purchased. Please contact our Customer Service Department at the address provided below if you have any questions or problems.

Warranty Service Support

Depending upon the circumstances and availability of technical service personnel, we may provide technical assistance and/or field service support, at no charge to the customer, to assist in the correction of warranty related problems. Contact our Customer Service Department at the address provided above to coordinate Warranty Service Support.

Spike Puller / RRP# 465393 [Rev 13 (5.2019)]

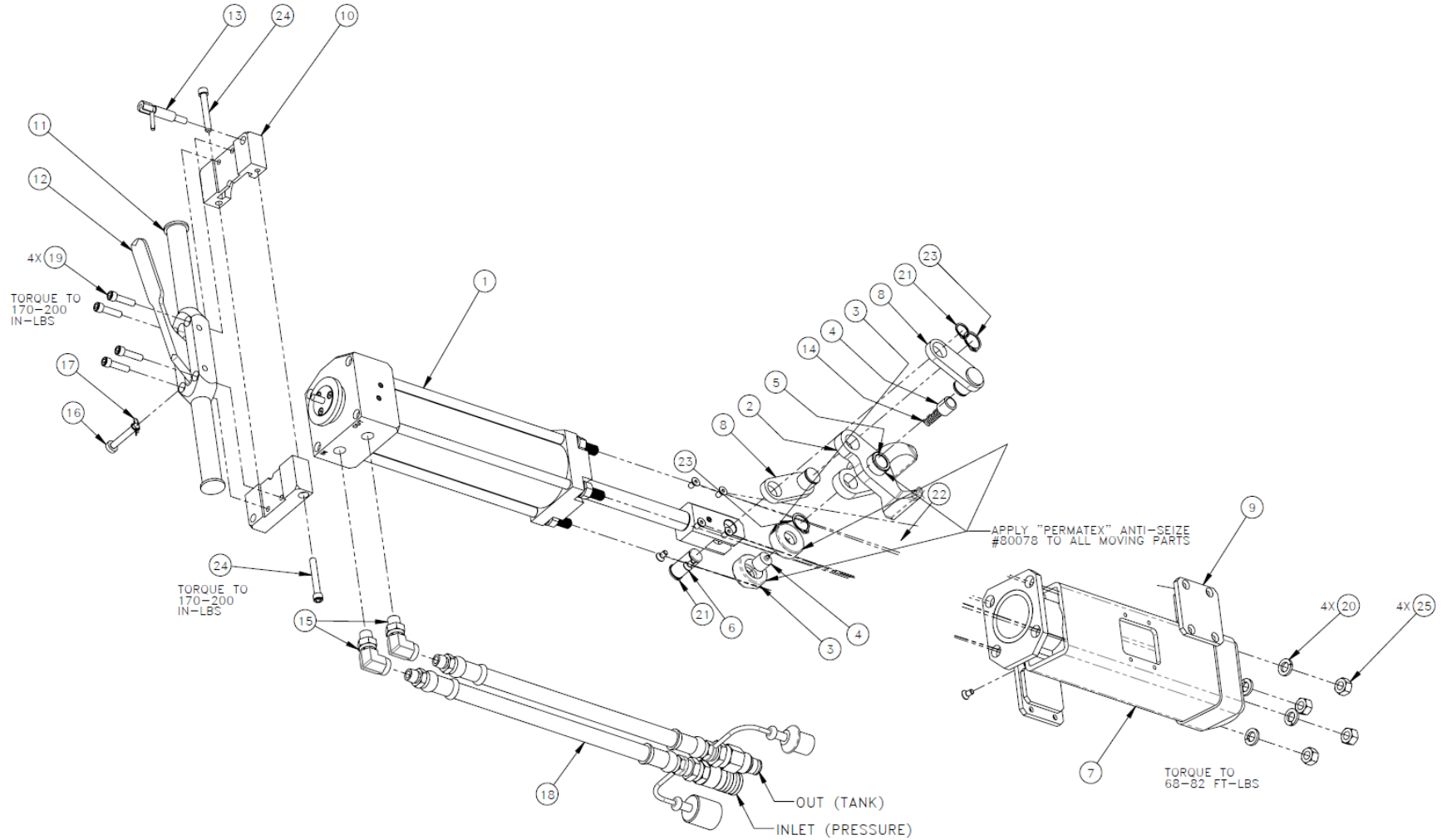

Spike Puller / RRP# 465393 Parts List

NO.	QTY	DESCRIPTION	PART NO.
1	1	CYLINDER	10000138
2	2	JAW	10018863
3	2	SPACER, JAW	10018865
4	2	CAP, FRICTION	10018867
5	1	PIN, PIVOT	10018869
6	1	PIN, CLEVIS	10018871
7	1	CHUTE	10018874
8	2	LINK	10019813
9	2	COVER, CHUTE	25018883
10	2	CAP, INDEXING	25018884
11	1	HANDLE	25018885
12	1	HANDLE, CONTROL	25018886
13	1	PLUNGER, HANDLE PULL	25018904
14	1	SPRING, COMPRESSION	25018907
15	2	FITTING, SWIVEL ELBOW	25018908
16	1	PIN, CLEVIS	25018912
17	1	PIN, COTTER	25018913
18	1	HOSES, WHIP	26002497
19	4	SCR, SOC: .31-18 X 1.25	400789
20	4	WASHER, LOCK: .5 SPLIT	400909
21	2	RING, RETAINING .75 DIA EXT	405390
22	8	SCR, SOC FLT: .25-20 X .5	406143
23	2	RING, RETAINING: .875 DIA EXT	406147
24	2	SCR, SOC: .31-18 X 2.25	407654
25	4	NUT, HEX: .5-13	491362

Section 6: Warranty Terms and Conditions

Warranty Period

Each new machine and new parts of our manufacture are warranted against defects in material and workmanship for one year from the date of shipment from our factory.

When contacting customer service for factory parts, service or warranty support please provide the:

- Racine Railroad Products Model
- Serial Number
- Any locally assigned identification

Vendor Parts Warranty Period

Other equipment and parts used, but not manufactured by Racine Railroad Products, Inc., are covered directly by the manufacturer's warranty for their products.

Warranty Parts and Service

We will repair or replace, without charge, F.O.B. factory, Racine, Wisconsin, USA, any part Racine Railroad Products manufactures which is proven to be defective during the warranty period.

Material claimed defective must be returned, if requested, to the factory within 30 days from the date of the claim for replacement. Ordinary wear and tear, abuse, misuse, and neglect are not covered by this warranty. Depending upon the circumstances, we may provide technical assistance and/or technical service support, without charge, to assist in the correction of warranty related problems.

Non-Warranty Parts and Service

Material damaged through normal wear and tear, abuse, misuse and/or neglect are not covered by our warranty and should be ordered directly from Customer Service.

Note: Parts for models that are no longer in production may not be available.

Non-Warranty Parts Orders

When placing a parts order please provide the following information:

- Company Name and Billing Address
- Purchase Order Number and Issuing Authority
- Shipping Address
- Special Handling Instructions
- Contact Phone Number
- Machine Model and Serial Number
- Part Numbers and Quantities Being Ordered

Note: *Please use Racine Railroad Products part numbers when ordering parts.* Racine Railroad Products part numbers are shown in the parts lists and drawings of this manual and have only six (6) numbers.

Any part number with other than six numbers (e.g., contains alpha-numeric characters) is a Vendor Part Number and **not** a Racine Railroad Products part number